

### FEATURES

- Double rocker switch insert (reference 8300018)
- Available cover colours (sold separately, with reference 83000190X, where X = colour):
  - Anthracite (X=5)
  - Silver (X=6)
  - Gloss white (X=8)
  - Matt white (X=9)
- Flush fitting with ZS55 series 1 to 4-gang frames (sold separately, with reference 980000Y0X, where Y = number of gangs, X = colour)
- The use of fixing clamps is optional. This reference is sold separately (reference ZACZSCLA2)
- Dimensions 55 x 55 x 20 mm
- Low profile: the decorative frame protrudes 9.5 mm from the wall
- Flush-mounted installation
- In compliance with the standard IEC 60669-1

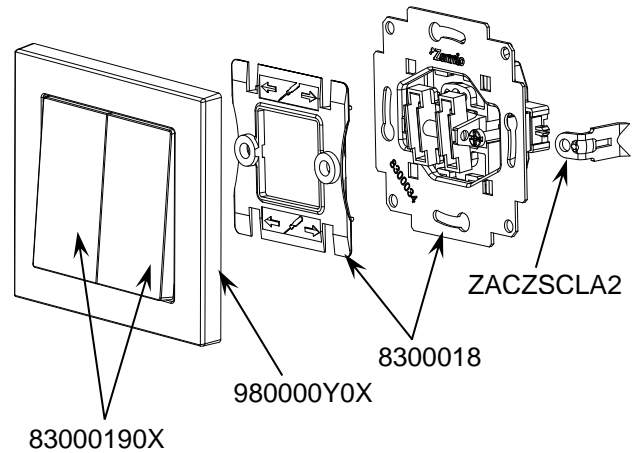

Figure 1. Double one-way rocker switch

GENERAL SPECIFICATIONS	
CONCEPT	DESCRIPTION
Rated voltage	250 VAC
Rated current	10 AX
Function type	1+1
Connection method	Screwless terminal block
Maximum cable cross-section	2.5 mm <sup>2</sup> (IEC) / 12 AWG (UL)
Operation temperature	0 .. +40 °C
Storage temperature	-20 .. +55 °C
Operation humidity	5 .. 95% RH
Storage humidity	5 .. 95% RH
Degree of protection	IP20, clean environment
Installation	Independent device to be installed in back boxes
Weight	69 g
Housing material	PC+ABS FR V0 halogen free

## INSTALLATION INSTRUCTIONS

1. Connect the cables to the terminals and fix the metal plate into a square or round flush back box by using the screws from the back box (fixing clamps can optionally be used). Check that the plate is correctly leveled.
2. Mount the frame on the insert by using the fixing plate.
3. Fix the covers into their final position checking that the device is duly fixed.

To remove it, proceed the reverse way considering that the fixing plate must be removed with the help of a screwdriver by levering the areas marked on the piece itself.

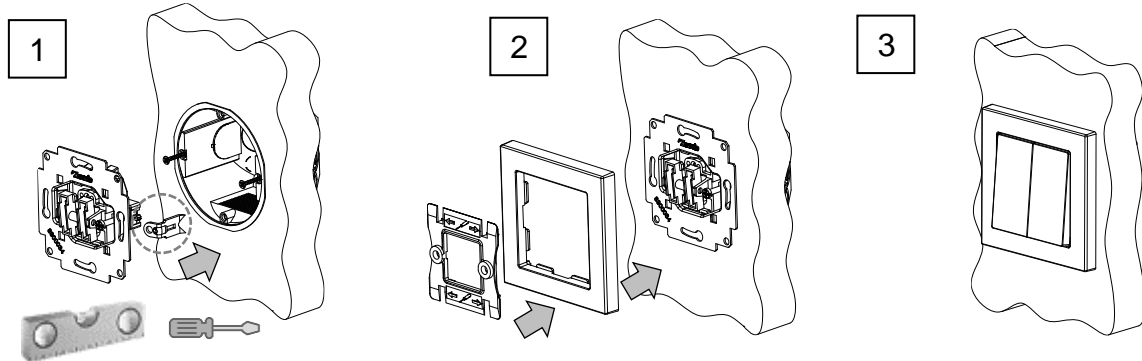

## DIMENSIONS (mm)

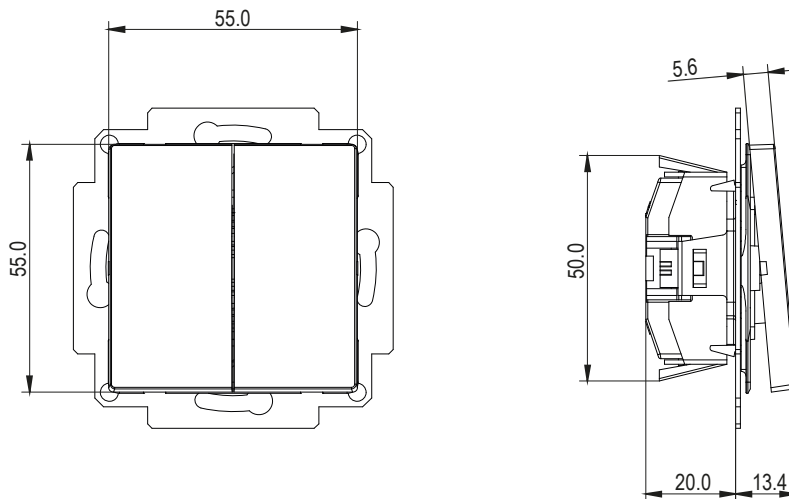

## WIRING DIAGRAMS

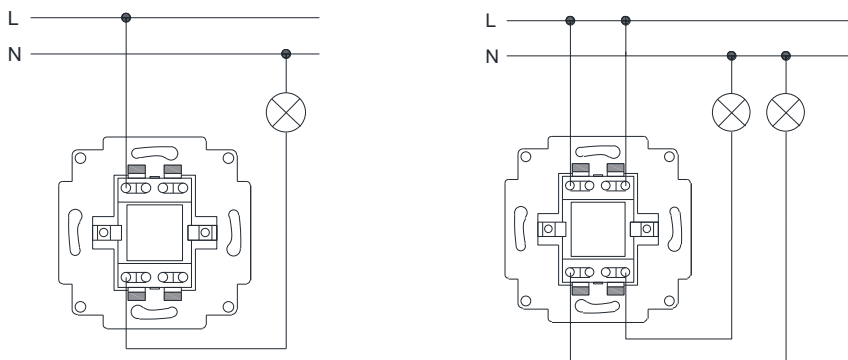

## SAFETY INSTRUCTIONS AND ADDITIONAL NOTES

- Installation should only be performed by qualified professionals according to the laws and regulations applicable in each country.
- The facility must be equipped with a device that ensures the omnipolar sectioning. Installation of a 10 A mini-circuit-breaker is recommended. To prevent accidents, it must remain open in case of manipulation of the device.
- Keep the device away from water (condensation over the device included) and do not cover it with clothes, paper or any other material while in use.
- The WEEE logo means that this device contains electronic parts and it must be properly disposed of by following the instructions at <https://www.zennio.com/en/legal/weee-regulation>.

